

# Float Equipment & Cementing Plugs

**Float Equipment** STM has been manufacturing high quality float equipment since 1987, In 1999 STM success fully commissioned a state of the art computer controlled API test loop facility for testing float equipment. STM float equipment is manufactured by in house CNC machinery to ensure conformity and quality. Once machined, components are individually inspected and certified by our independent quality team. Standard STM float equipment meets or exceeds API requirements.



## Float Equipment

### Float Shoes Type

FLOAT SHOE PLUNGER VALVE

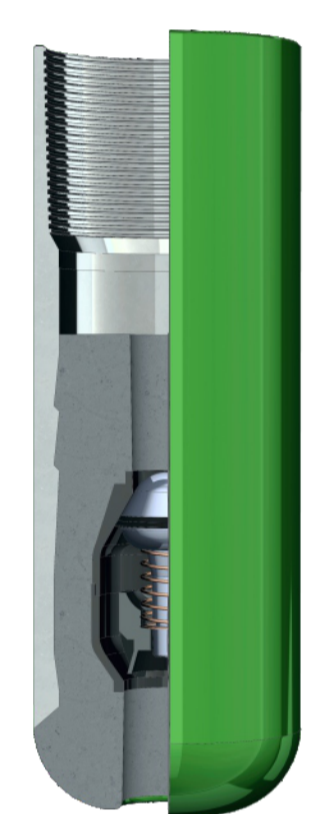

FLOAT SHOE AUTO FILL UP VALVE

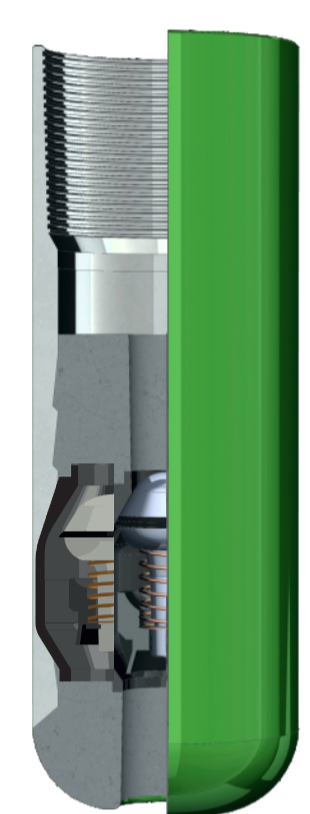

FLOAT SHOE SIDE JET

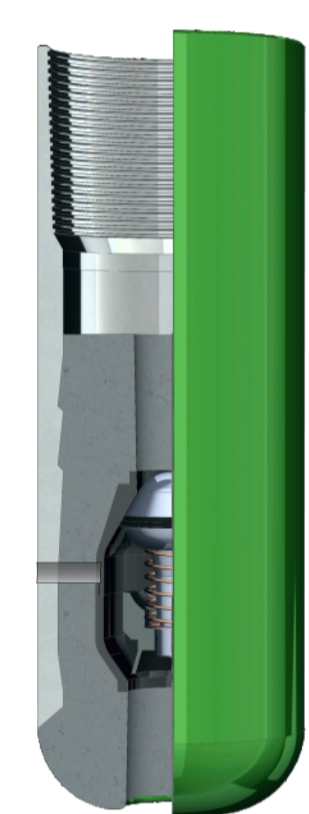

FLOAT SHOE DOWN JET



### Float Collar Type

FLOAT COLLAR PLUNGER VALVE

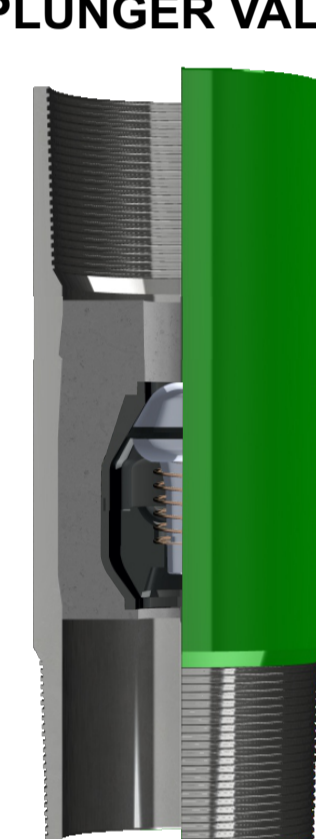

FLOAT COLLAR AUTO FILL UP VALVE

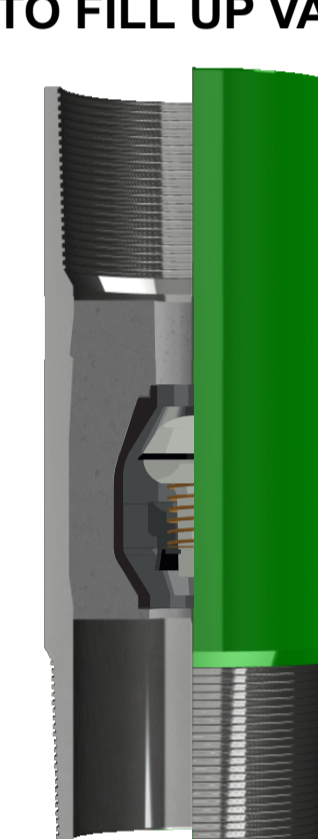

FLOAT COLLAR NON ROTATING

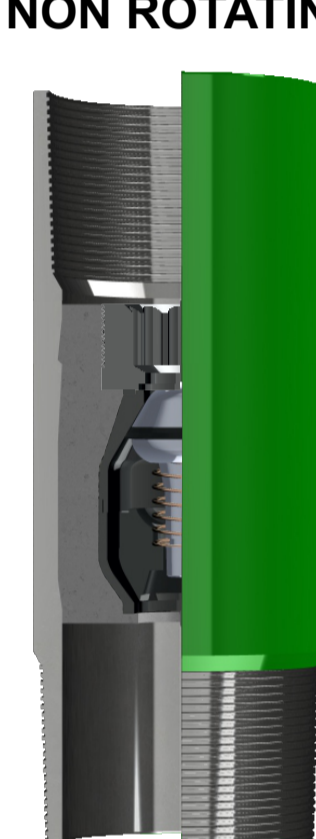

### Valve Type

PLUNGER VALVE

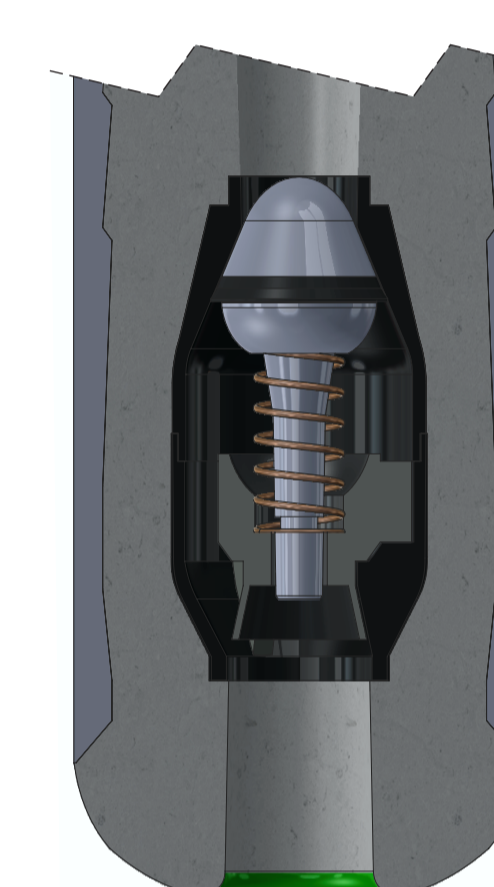

AUTO FILL UP VALVE

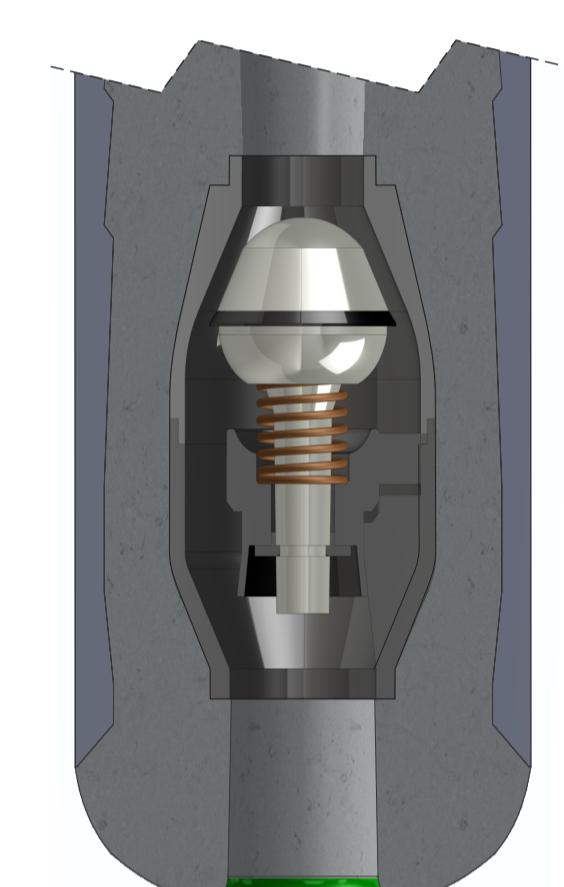

### Float Shoes and Float Collars

To meet modern requirements for **Float Shoes and Collars** to provide a positive seal in highly deviated, horizontal, high temperature and hostile environments STM has developed this new range of premium products capable of meeting and exceeding these demands.

Float Valve rated to 5,000psi @400F and flow rate minimum 6 bbl/min for casing size 5-1/2" & smaller and minimum 10 bbl/min for casing size 6-5/8" & larger with flow duration 24 hours.

STM Plunger Type float equipment is available in sizes ranging from 2 7/8" through to 30" and is fully PDC drillable, even the valve spring is constructed from PDC drillable materials. Sagtrade generally stocks standard API grades, K55, L80 & P110. Other grades may be available or can be procured, please consult with Sagtrade. Internal and external pressure applied should not exceed pressure rating of the casing.

### Float Equipment Valve

Sagtrade Murni's float valve is integral part of wiperlok system, incorporates of phenolic plunger valve, spring-loaded and all the materials are made from PDC drillable. There are three distinct sizes Float Valve for different Float Equipment sizes application.

## CEMENTING PLUGS

STM offers a complete range of cementing plugs in sizes ranging from 2 7/8" through to 20". Our premium Casing Cementing Plugs are PDC drillable with heat resistance of 300 degrees F and are colour coded with bright orange bottom plugs are extremely durable with high abrasion resistance and able to withstand pressure differential of standard float equipment. STM can also provide high temperature Cementing Plugs. We also manufacture custom plugs to customer requirements.

### Non-Rotating Top & Bottom Plugs

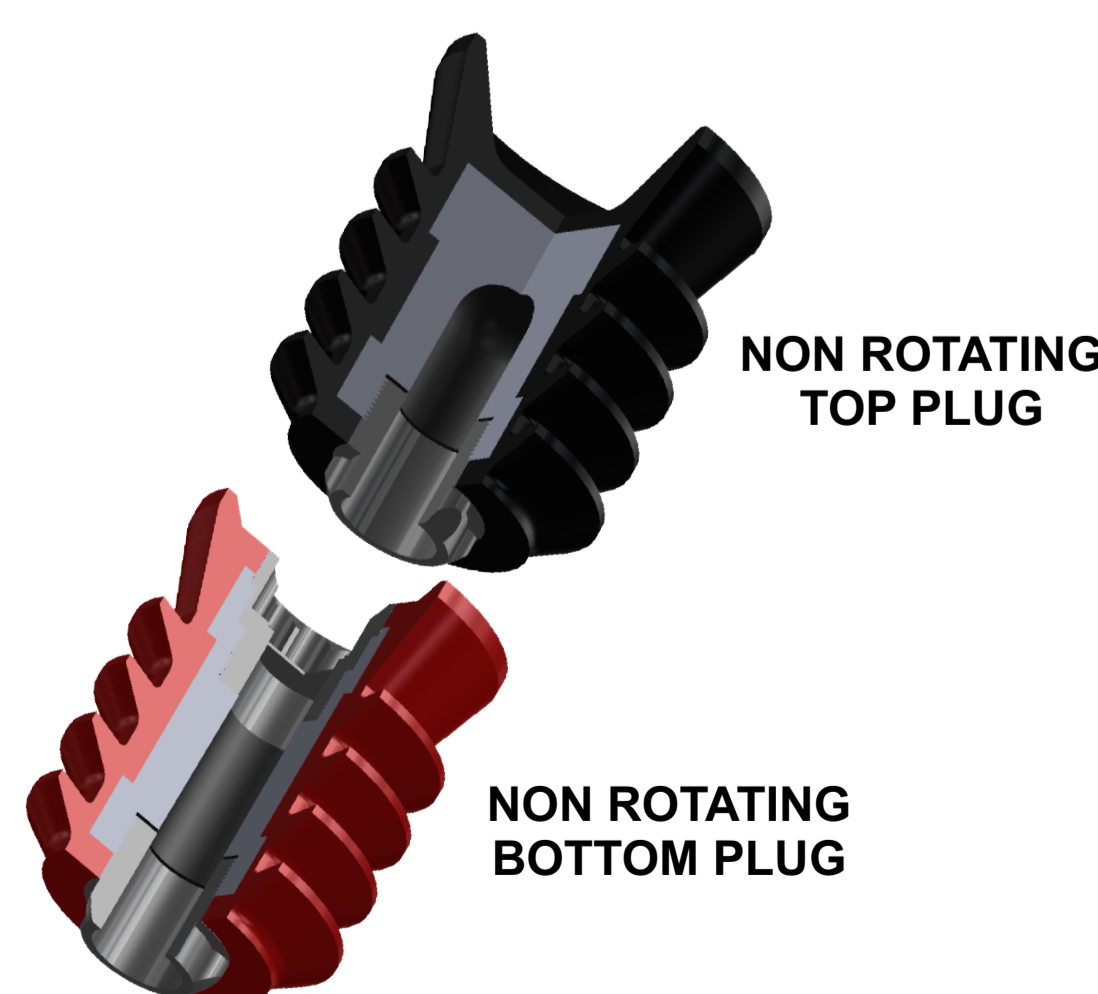

### High Pressure Non-Rotating Top & Bottom Plugs

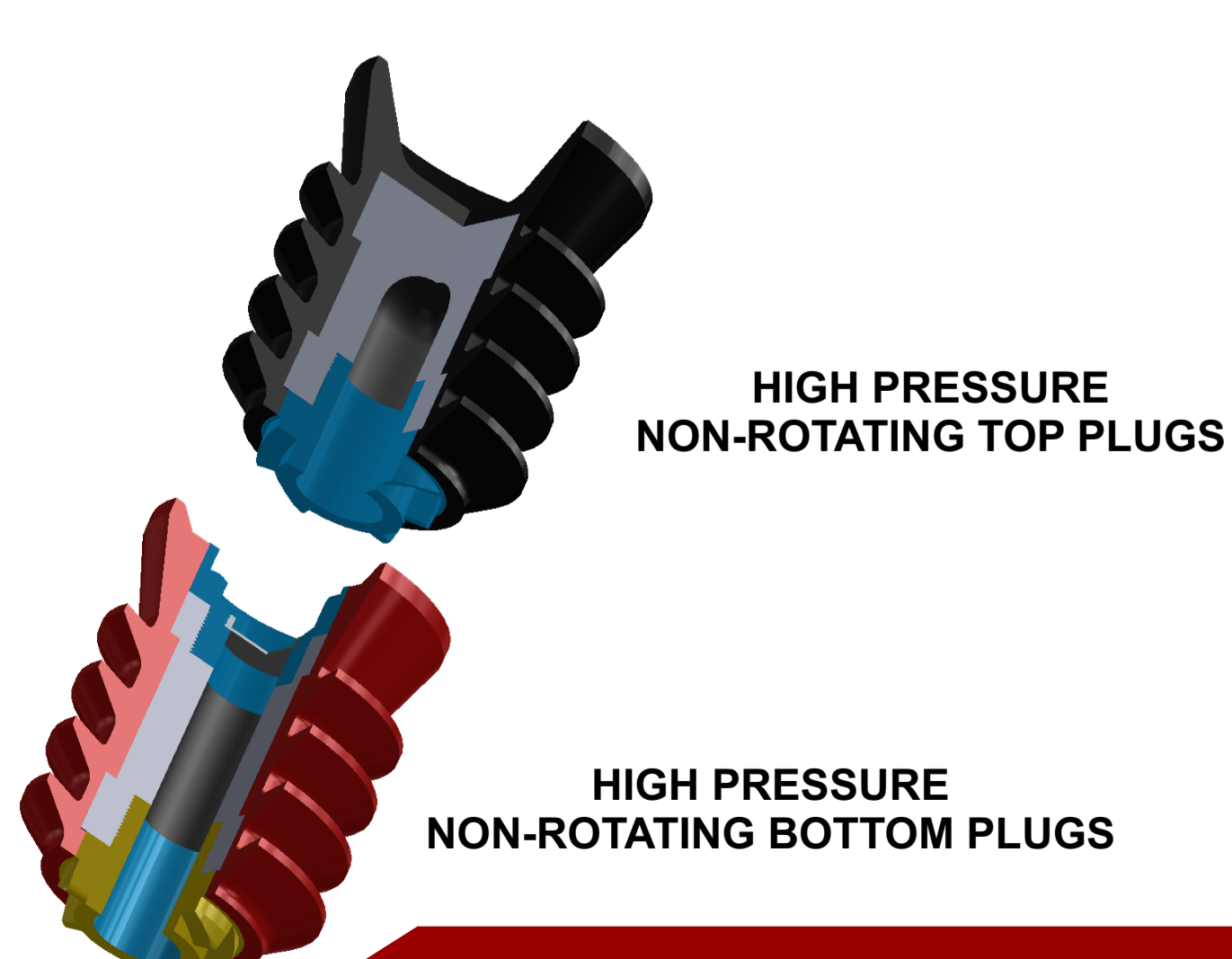

### Standard Top & Bottom Plugs

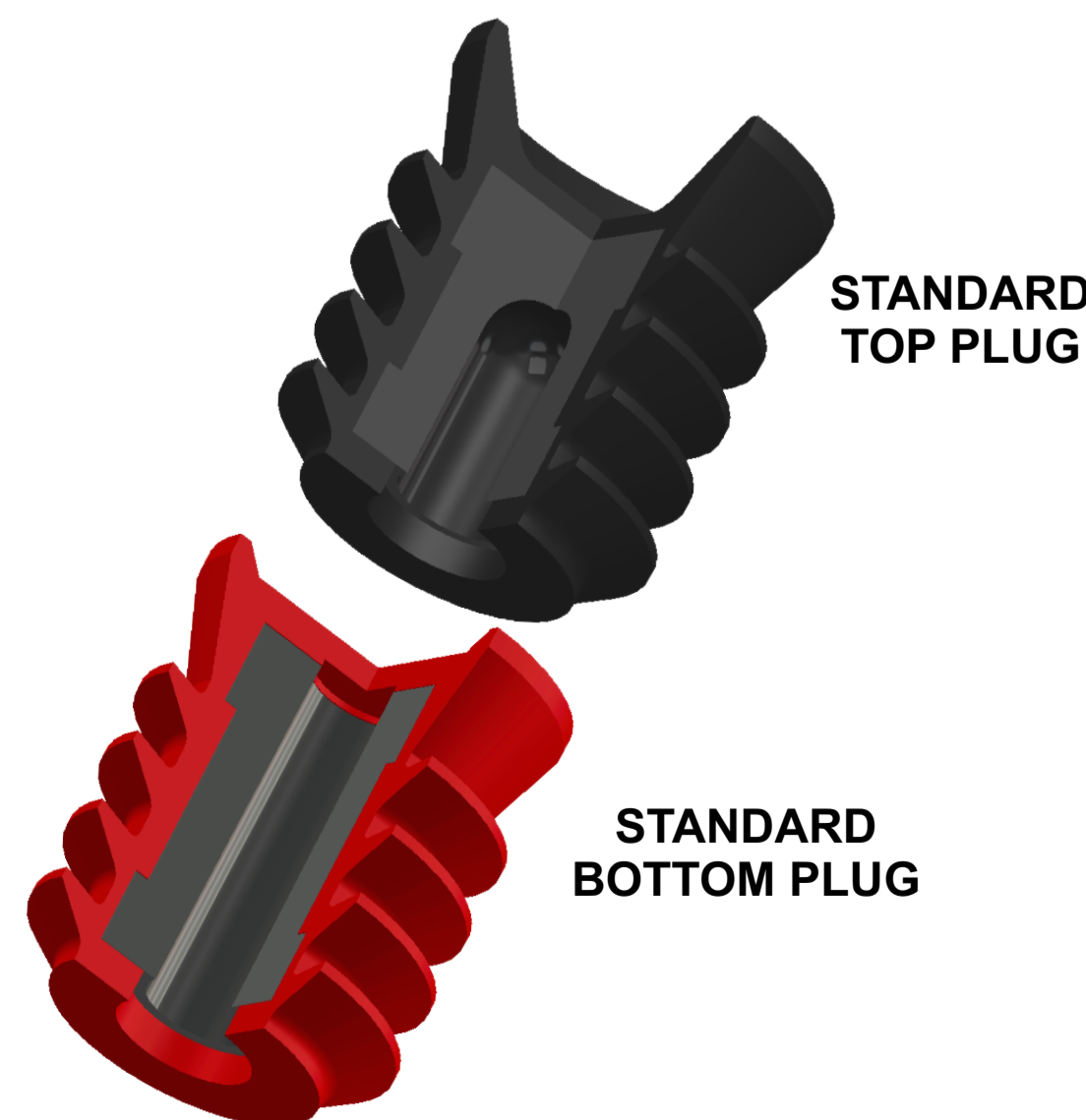

## SCHEMATIC RIH

